

GROUP 1 PUMPS- EUROPEAN STANDARD

VERSION: G18 P1

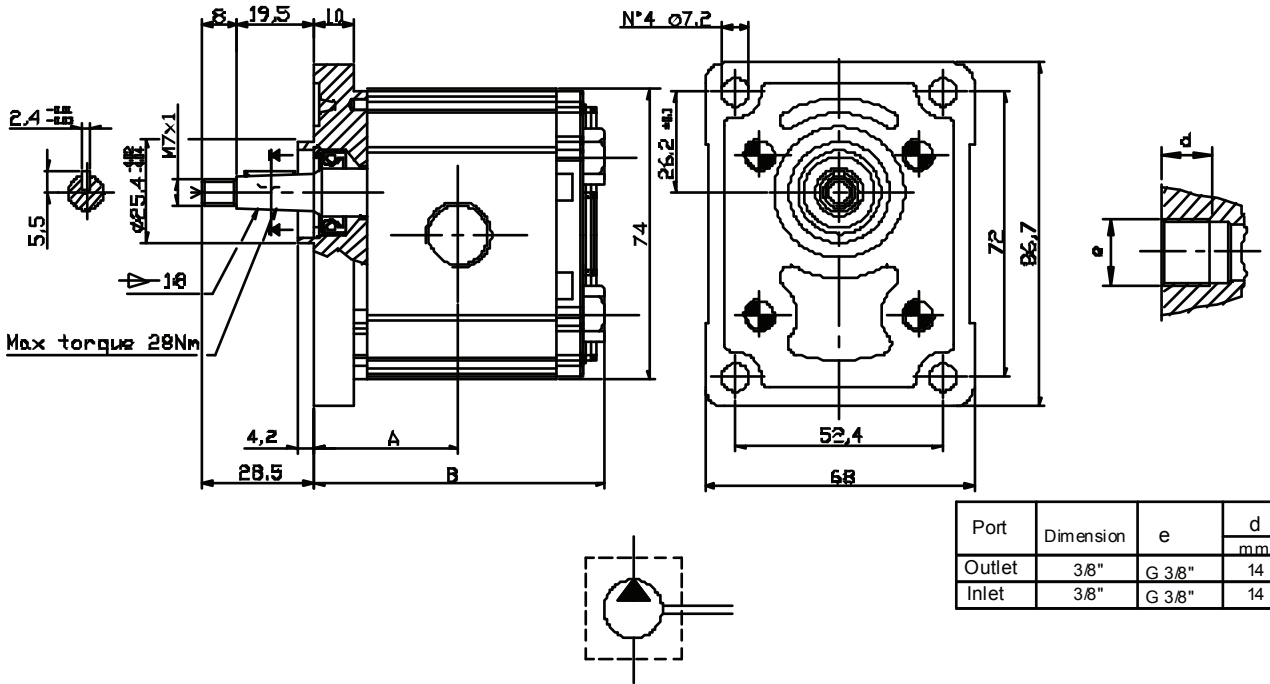

Type	Displacement (cc/rev)	Max working pressure P1 (bar)	Peak pressure P3 (bar)	Max speed (r.p.m)	Dimension (mm)		Absorbed torque at 150 bar (Nm)	Code (Anti-clockwise)	Code (Clockwise)
					A	B			
OT 100 P07	0.73	200	240	5000	31.30	64.5	1.8	PS1007061S	PS1007061D
OT 100 P11	1.05	240	280	5000	31.90	65.6	2.4	PS1007062S	PS1007062D
OT 100 P16	1.45	260	300	5000	32.75	67.3	4.2	PS1007063S	PS1007063D
OT 100 P20	1.80	260	300	5000	33.45	68.7	5.2	PS1007064S	PS1007064D
OT 100 P25	2.45	260	300	5000	34.50	70.8	6.7	PS1007065S	PS1007065D
OT 100 P32	3.05	260	300	5000	35.50	72.8	8.3	PS1007066S	PS1007066D
OT 100 P40	3.80	260	300	4500	36.90	75.6	10.1	PS1007067S	PS1007067D
OT 100 P49	4.70	240	280	4500	38.45	78.7	12.7	PS1007068S	PS1007068D
OT 100 P58	5.55	200	240	4000	40.00	81.8	15.0	PS1007069S	PS1007069D
OT 100 P65	6.25	190	230	3750	41.25	84.3	16.8	PS1007070S	PS1007070D
OT 100 P79	7.60	170	220	3500	43.60	89.0	20.5	PS1017071S	PS1017071D

EXAMPLE OF ORDERING CODE

OT100 P 20 S / G 18 P1

Series

Pump

Displacement (see above table)

Rotation

S Anti-clockwise

D Clockwise

European standard flange

Taper shaft (1:8)

Body with threaded ports (BSP)

AVAILABLE FOR QUANTITIES