

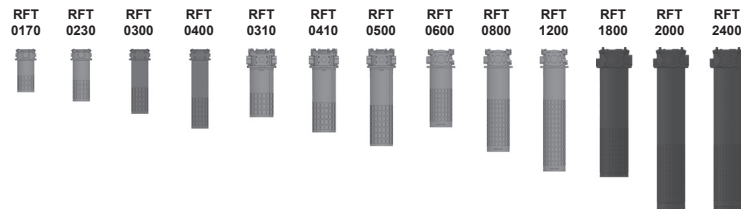

## Return Line Filter RFT

Flow direction from in to out  
up to 2,400 l/min, up to 10 bar



### 1. TECHNICAL SPECIFICATIONS

#### 1.1 FILTER HOUSING

##### Design

This filter system provides an economic solution for full-flow return line filtration. The filter head is mounted on the tank. The housing tube can be supplied in various optional versions. Firstly as a closed tube with the outlet opening facing downwards or with a closed base and rows of opening holes at the height of the tank's oil level. In the second version, separating air from the oil is made easier. The magnetic core is connected to the filter element via a bayonet fitting, guaranteeing effective magnetic pre-filtration.

The filter housings are designed in accordance with international regulations. They consist of a filter cover, filter head, housing tube and element location spigot.

The element is top-removable!

##### Standard equipment

- Magnetic core integrated into clamp (only for RFT 0170 – 0500)
- Magnetic core integrated into cover (only for RFT 0600 – 2400)
- with housing tube with diffuser
- with bypass valve

#### 1.2 FILTER ELEMENTS

HYDAC filter elements are validated and their quality is constantly monitored according to the following standards:

ISO 2941, ISO 2942, ISO 2943, ISO 3724, ISO 3968, ISO 11170, ISO 16889

Filter elements are available with the following pressure stability values:

Glass fibre (ULP): 6 bar  
Glass fibre with pre-filter (UMC): 6 bar  
Wire mesh (WPI): 6 bar

Other filtration ratings on request.

#### 1.3 FILTER SPECIFICATIONS

Nominal pressure	10 bar
Temperature range	-30 °C to +120 °C
Material of filter cover	RFT 0170 – 0400: EN-AC-43300 RFT 0310 – 1200: EN-AC-47100 RFT 1800 – 2400: EN-AC-43000
Material of filter head	RFT 0170 – 1200: EN-AC-43300 RFT 1800 – 2400: EN-AC-43400
Material of housing tube	Steel
Bypass cracking pressure	2.5 bar (others on request)

#### 1.4 SEALS

NBR (= Perbunan)

#### 1.5 INSTALLATION

As in-tank filter

#### 1.6 SPECIAL MODELS AND ACCESSORIES

- without magnetic core
- without housing tube (only RFT 0170 – 500)
- with protective tube, base open
- Outlet grille in openings in housing tube
- Seals made of FKM

#### 1.7 SPARE PARTS

See original spare parts list

#### 1.8 COMPATIBILITY WITH HYDRAULIC FLUIDS ISO 2943

- Hydraulic oils H to HLPD DIN 51524
- Lubrication oils DIN 51517, API, ACEA, DIN 51515, ISO 6743
- Compressor oils DIN 51506
- Biodegradable operating fluids VDMA 24568 HETG, HEES, HEPG

#### 1.9 IMPORTANT INFORMATION

- Filter housings must be earthed
- When using electrical clogging indicators, the electrical power supply to the system must be switched off before removing the clogging indicator connector

#### Symbol

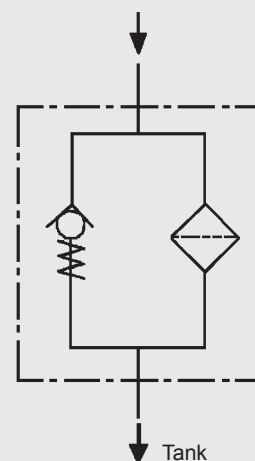

## 2. MODEL CODE (also order example)

RFT 0600 UMC 010 V M B H L N J0 VX X 1 /-XXX

### 2.1 FILTER ASSEMBLY

#### Filter type

RFT

#### Size

0170, 0230, 0300, 0400, 0310, 0410, 0500, 0600, 0800, 1200, 1800, 2000, 2400

#### Filter material

ULP glass fibre  
 UMC glass fibre with pre-filter  
 WPI wire mesh

#### Filtration rating in µm

ULP 010, 025  
 UMC 010, 020  
 WPI 100

#### Bypass valve

C with bypass valve 0.8 bar  
 V standard: with bypass valve 2.5 bar  
 X without bypass valve

#### Magnetic core

M with magnetic core  
 X without magnetic core

#### Setting range

B 10 bar

#### Type and size of port

Type	Port	Size of filter												
		0170	0230	0300	0400	0310	0410	0500	0600	0800	1200	1800	2000	2400
F	E1: G1½	●	●	●	●									
G	E1: SAE DN 50 (2") E2: G1¼					●	●	●						
H	E1: SAE DN 80 (3") E4: SAE DN 50 (2") E5: G1¼									●	●	●		
I	E1: SAE DN 65 (2½") E4: SAE DN 40 (1½") E5: G1									●	●	●		
J	E2: SAE DN 40 (1½")					●	●	●						
K	E1: SAE DN 40 (1½") E2: G1	●	●	●	●									
N	E1: SAE DN 80 (3")											●	●	●
P	E1: SAE DN 100 (4")											●	●	●

others on request

#### Tube version

X without housing tube (only RFT 0170, 0230, 0300, 0400, 0310, 0410, 0500)  
 B with housing tube, base open  
 L standard: with diffuser (perforated)  
 R with diffuser (openings with outlet grille)

#### Seals

N NBR (Perbunan)  
 V FKM

#### Position of clogging indicator

JA both holes bored G¾; both closed up with plugs  
 J1 as per specifications in 4. of this data sheet  
 J2 as per specifications in 4. of this data sheet  
 J0 without clogging indicator

#### Clogging indicator

VA visual / electrical  
 VE electrical  
 VO visual  
 VX no clogging indicator, sealed up with plugs

#### Response pressure of clogging indicator

C 0.8 bar  
 D 2.0 bar  
 X none (if no clogging indicator is installed)

#### Modification number

X the latest version is always supplied

#### Supplementary details

## 2.2 REPLACEMENT ELEMENT

UMC-0010-xxx-xxxx-x-N-RT /-XXX

### Filter material

ULP, UMC, WPI

### Filtration rating in $\mu\text{m}$

ULP 0010, 0025  
 UMC 0010, 0020  
 WPI 0100

### RT code

### Seals

N NBR (Perbunan)  
 V FKM

### Packaging

### Supplementary details

## 3. FILTER CALCULATION / DIMENSIONING

### 3.1 PERFORMANCE CURVES FOR FILTER ASSEMBLY

The total performance curves with element UMC ... apply to mineral oil with a density of  $0.86 \text{ kg/dm}^3$  and a kinematic viscosity of  $30 \text{ mm}^2/\text{s}$ .

#### RFT 0170

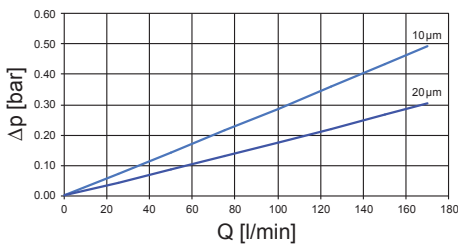

#### RFT 0230

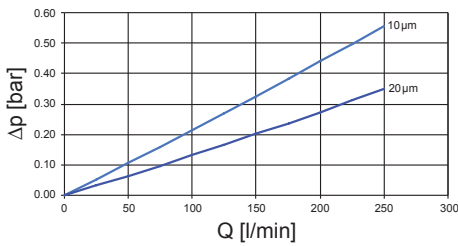

#### RFT 0300

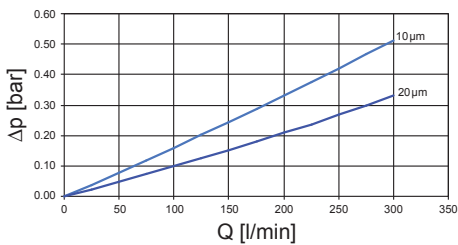

#### RFT 0400

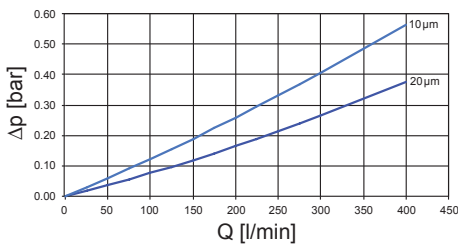

#### RFT 0310

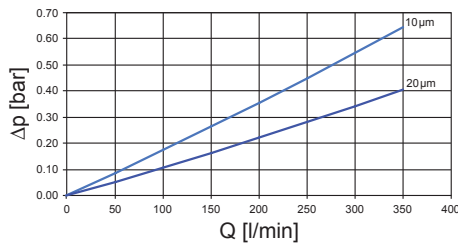

#### RFT 0410

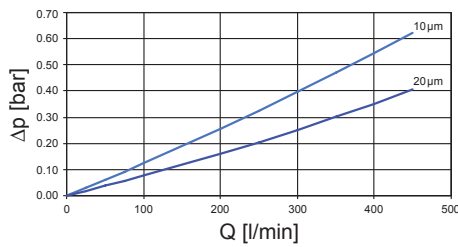

#### RFT 0500

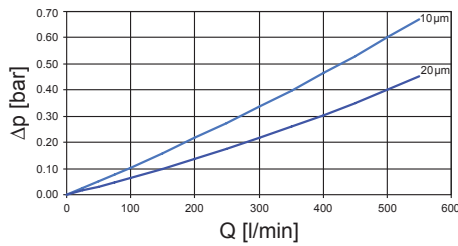

#### RFT 0600

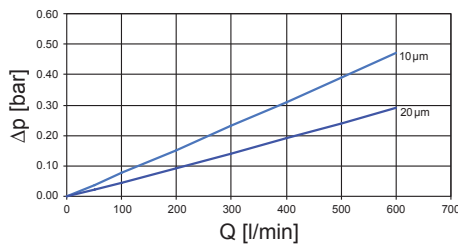

#### RFT 0800

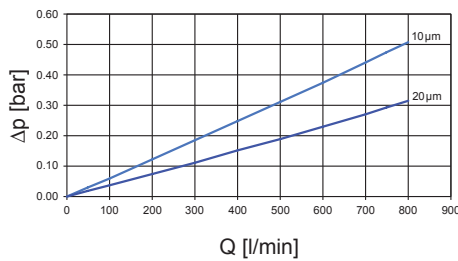

#### RFT 1200

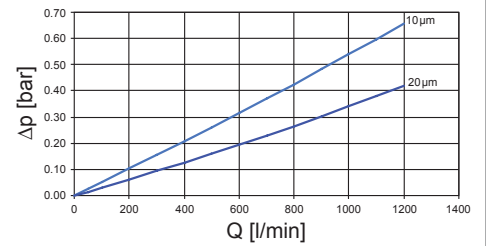

#### RFT 1800

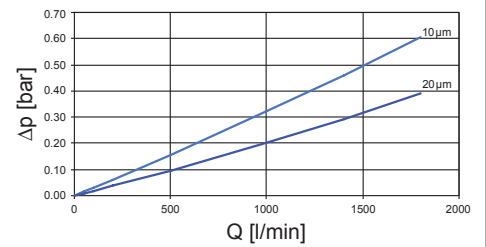

#### RFT 2000

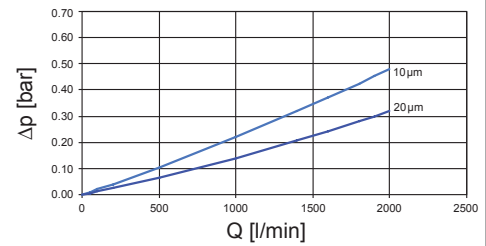

#### RFT 2400

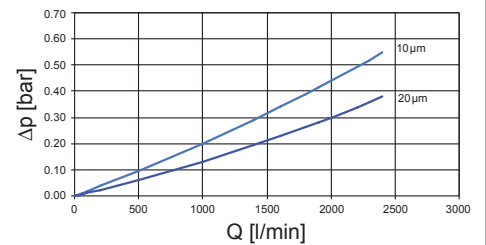

Other curves on request

## 4. DIMENSIONS

RFT 0170, 0230, 0300, 0400

Filter without tube

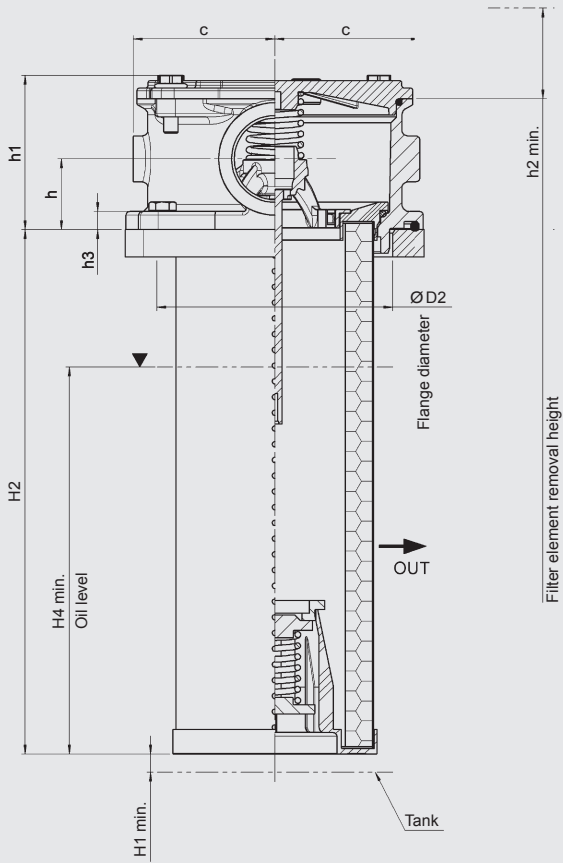

Filter with tube

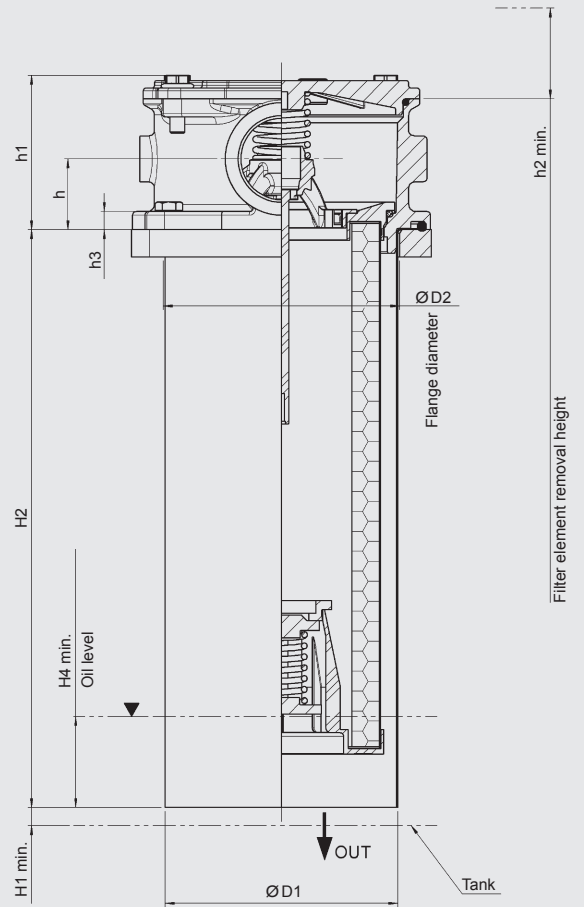

Filter with diffuser

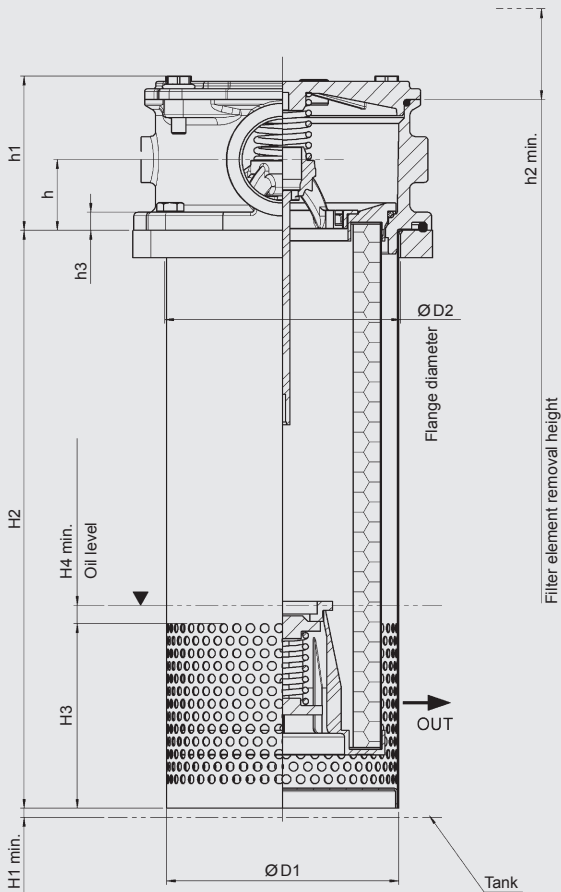

Filter with diffuser (opening with grille)

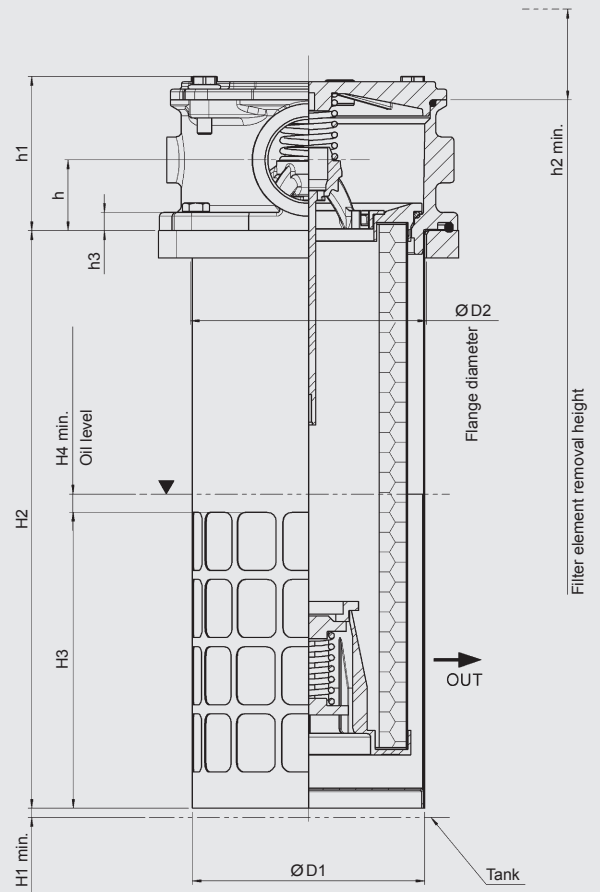

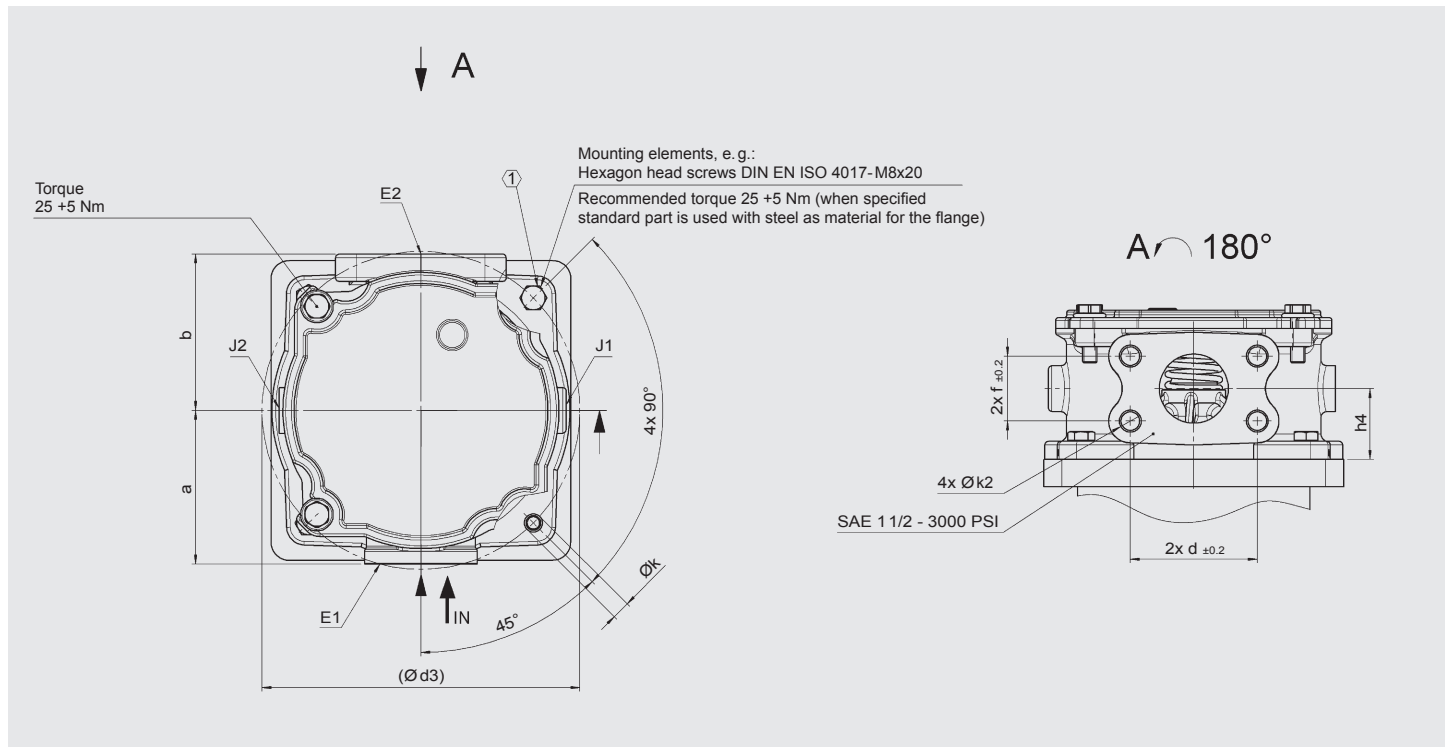

Type	Design	H1	H2	H3	H4	h	h1	h2	h3	h4	ØD1	ØD2	Ød3	a	b	c	d	f	Øk	Øk2	Weight incl. element [kg]		
RFT 0170	without tube	10	218	-	155	39	85	260	-	-	-	-	-	-	-	-	-	-	-	-	-	2.6	
	with tube		-	50	3.2																		
	with diffuser	5	247	102	10																	128	3.4
	Diffuser with opening		126	10	3.5																		
RFT 0230	without tube	10	289	-	203	39	85	330	10	-	-	-	-	-	-	-	-	-	-	-	-	2.9	
	with tube		-	50	3.5																		
	with diffuser	5	318	102	10																	128	3.7
	Diffuser with opening		163	10	3.8																		
RFT 0300	without tube	10	385	-	267	39	85	430	10	-	-	-	-	-	-	-	-	-	-	-	-	3.1	
	with tube		-	50	3.7																		
	with diffuser	5	414	102	10																	128	3.9
	Diffuser with opening		200	10	4.0																		
RFT 0400	without tube	10	499	-	336	39	85	540	10	-	-	-	-	-	-	-	-	-	-	-	-	3.4	
	with tube		-	50	4.1																		
	with diffuser	5	528	102	10																	128	4.3
	Diffuser with opening		237	10	4.4																		

\* unworked port

\*\* worked port

Filter without tube

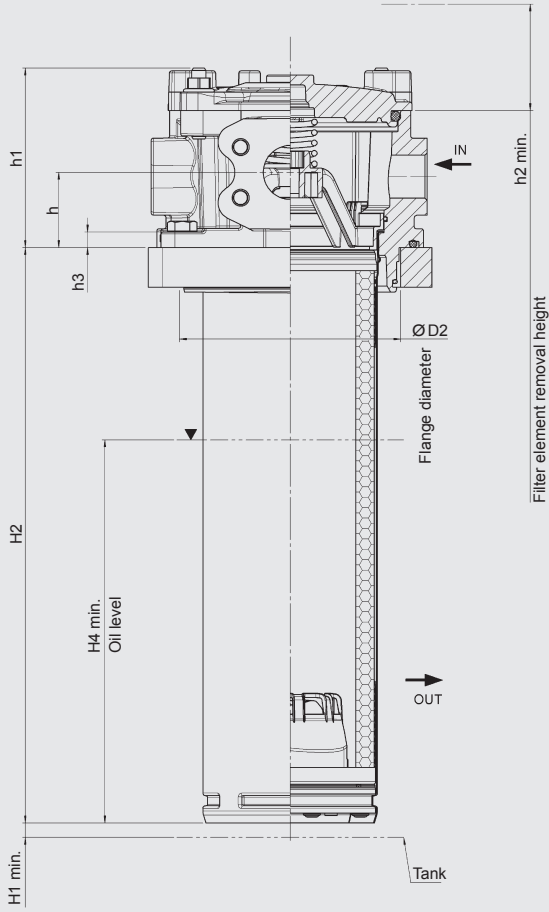

Filter with tube

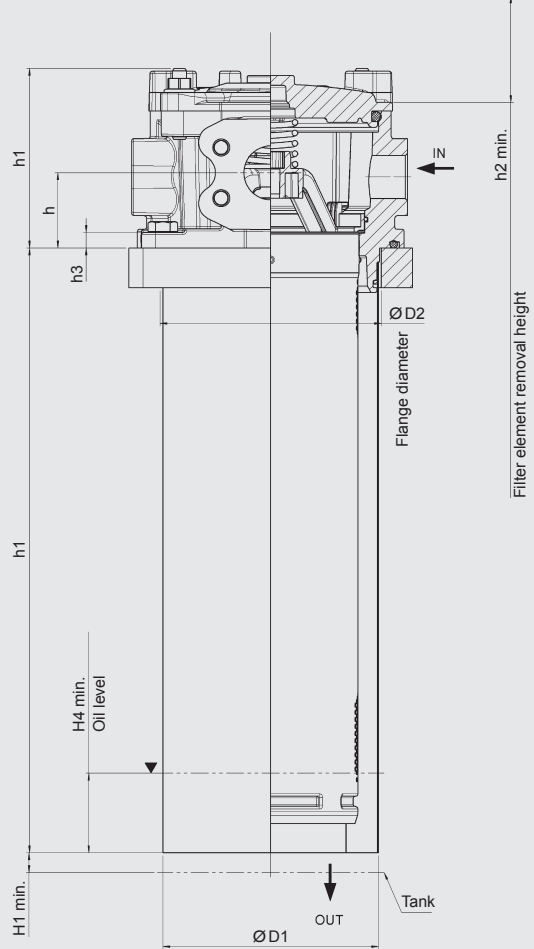

Filter with diffuser

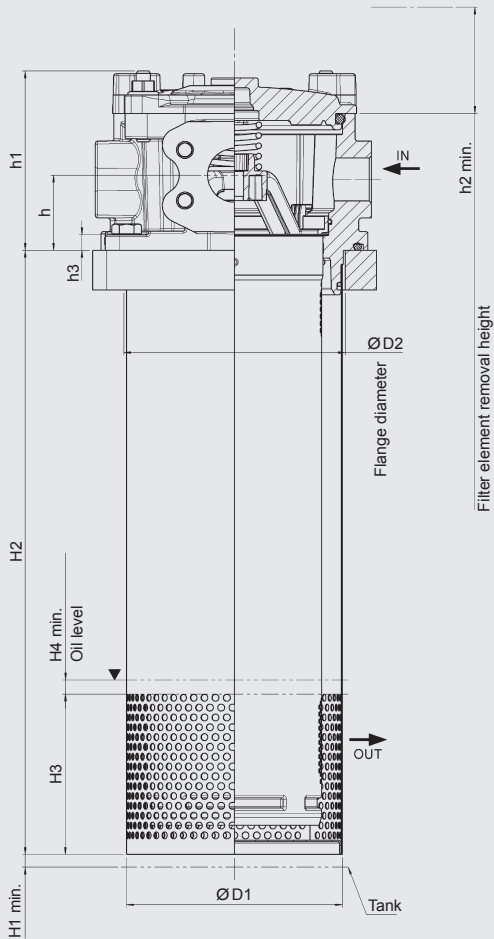

Filter with diffuser (opening with grille)

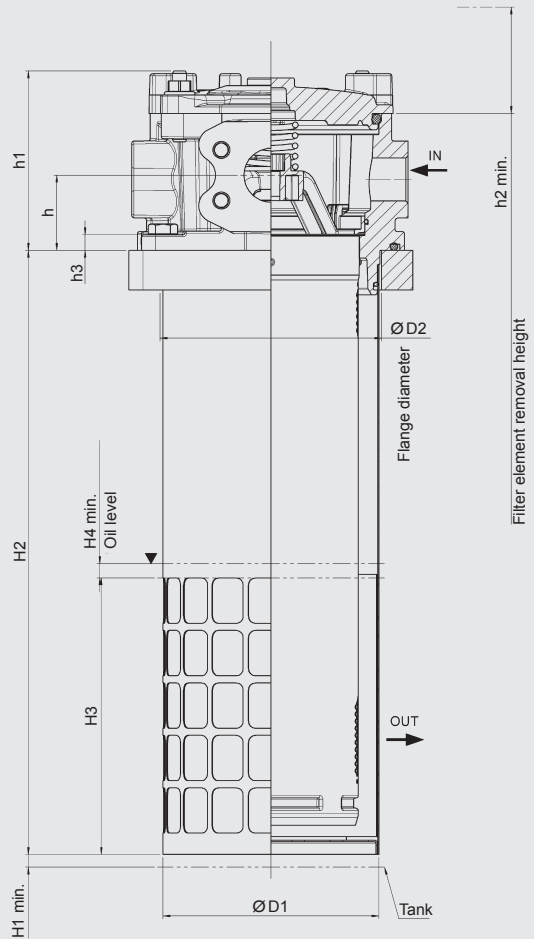

Mounting elements, e. g.:  
Hexagon nut with collar DIN EN ISO 1661 - M12  
Stud DIN 938 - M12x30 - 8.8  
Recommended torque 30 +5 Nm  
(when specified standard part is used  
with steel as material for the flange)

Torque  
25 +5 Nm

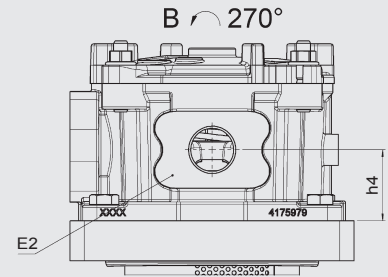
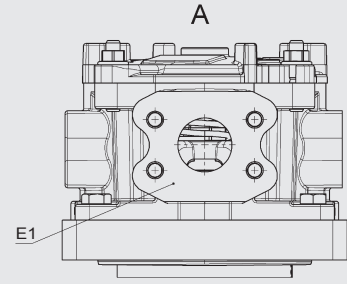
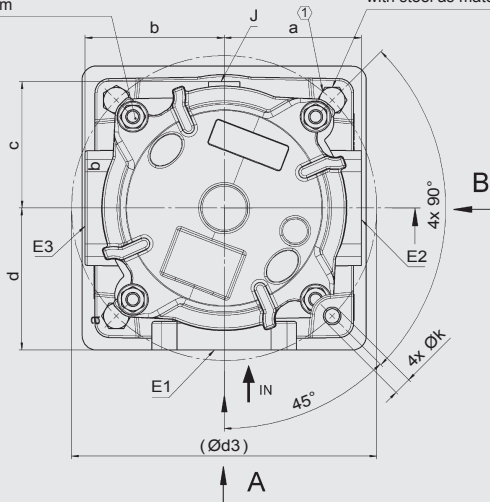

Type	Design	H1	H2	H3	H4	h	h1	h2	h3	h4	ØD1	ØD2	Ød3	a	b	c	d	Øk	Weight incl. element [kg]
RFT 0310	without tube	10	305.5	-	200	53	126.5	520	11	50	152	156	215	98.0*	98.0*	91*	100	12.5	4.2
	with tube		-	60	4.9														
	with diffuser	326	115	10	5.0														
	Diffuser with opening		5		158														5.1
RFT 0410	without tube	10	405.5	-	270	53	126.5	520	11	50	152	156	215	98.0*	98.0*	91*	100	12.5	4.5
	with tube		-	60	5.4														
	with diffuser	426	115	10	5.5														
	Diffuser with opening		5		195														5.6
RFT 0500	without tube	10	495.5	-	330	53	126.5	520	11	50	152	156	215	98.0*	98.0*	91*	100	12.5	5.0
	with tube		-	60	6.0														
	with diffuser	516	115	10	6.1														
	Diffuser with opening		5		270														6.2

\* unworked port

\*\* worked port

Filter with tube

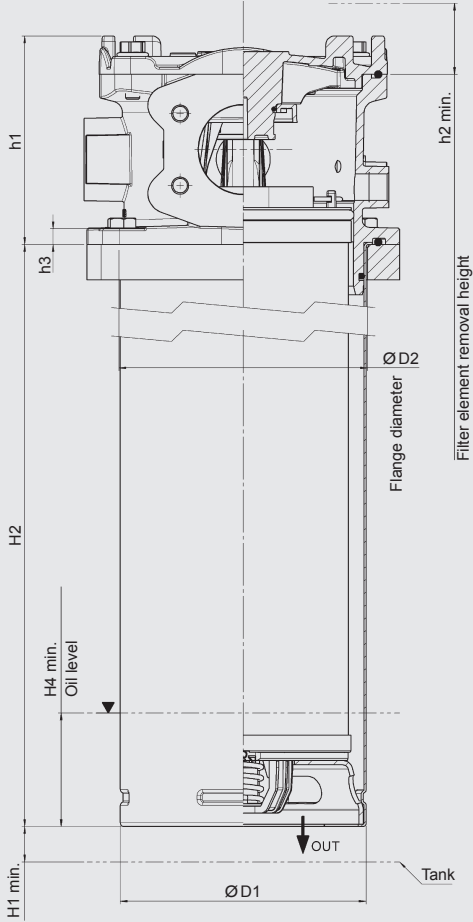

Filter with diffuser

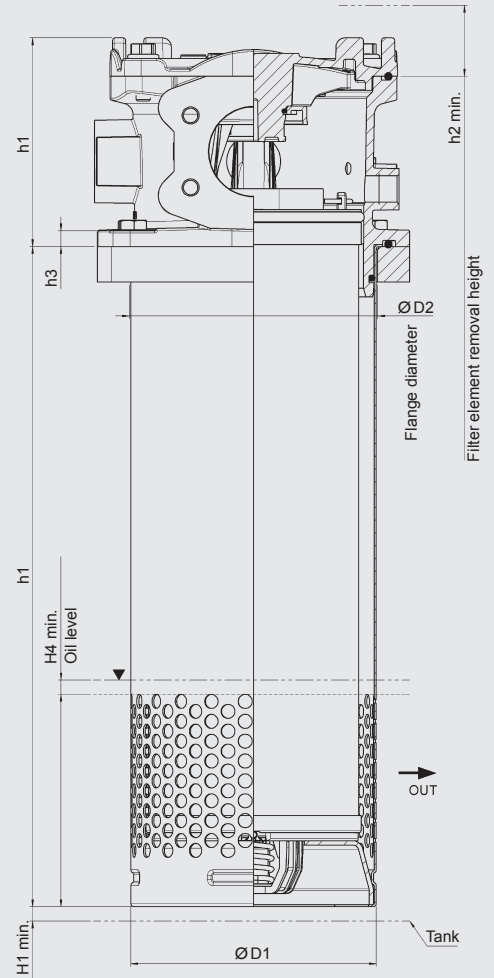

Filter with diffuser (opening with grille)

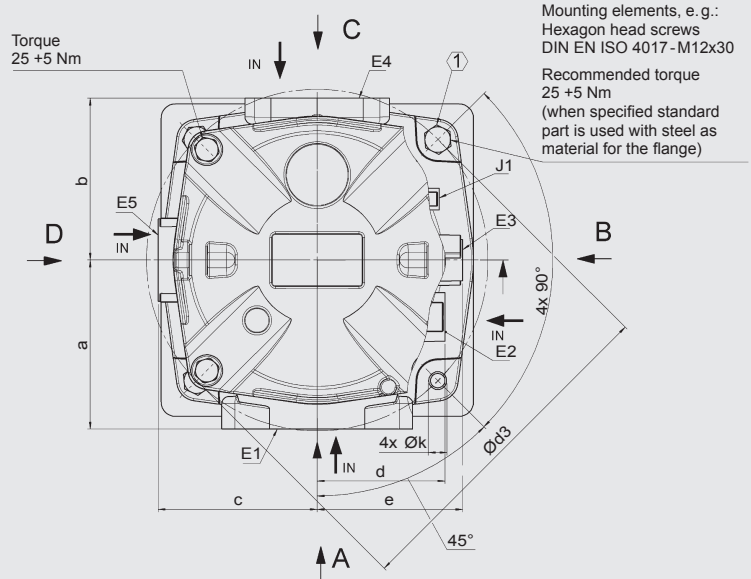
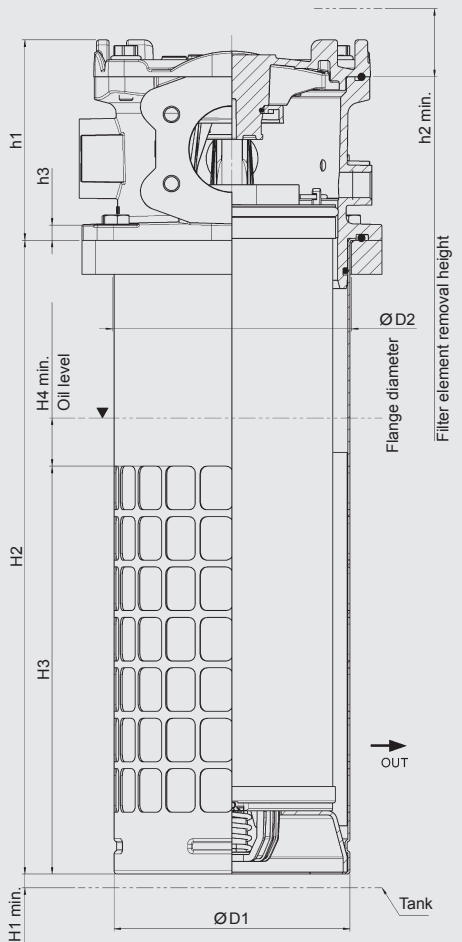



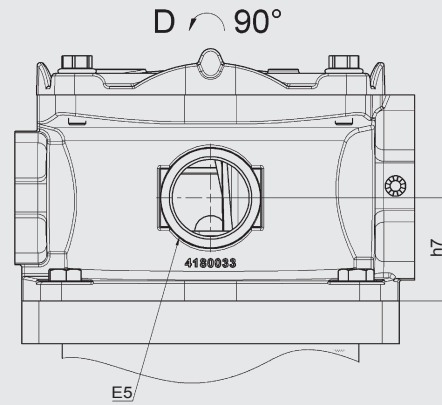
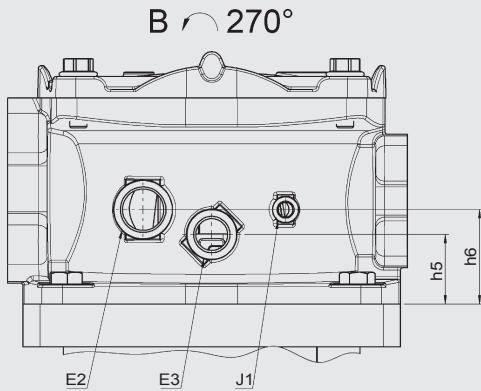
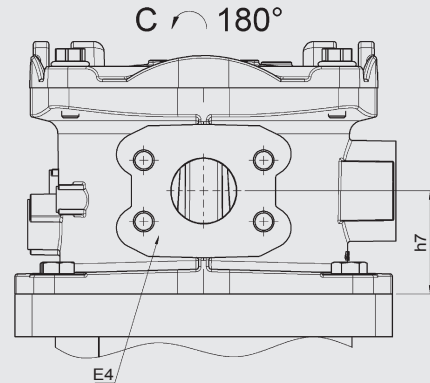
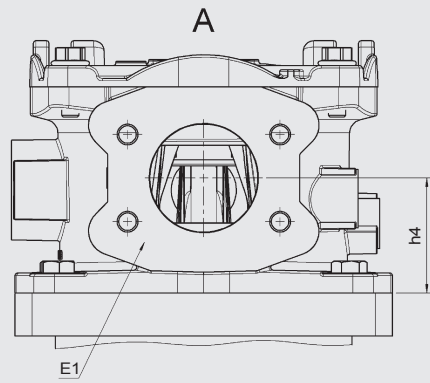

Type	Design	H1	H2	H3	H4	h	h1	h2	h3	h4	ØD1	ØD2	Ød3	a	f	f2	g	g2	Øk	Øk2	Weight incl. element [kg]
RFT 0600	with tube	10	481	-	80	41.5	112	500	13	51	173	175	220	107*	69.9	77.8	35.7	42.9	12.5	M12 18 deep	12.0
	with diffuser	5		140	10																12.2
	Diffuser with opening	5		290	10																12.3
RFT 0800	with tube	10	674	-	80	41.5	112	700	13	51	173	175	220	107*	69.9	77.8	35.7	42.9	12.5	M12 18 deep	12.8
	with diffuser	5		140	10																13.0
	Diffuser with opening	5		400	10																13.1
RFT 1200	with tube	10	828	-	80	41.5	112	900	13	51	173	175	220	107*	69.9	77.8	35.7	42.9	12.5	M12 18 deep	15.7
	with diffuser	5		140	10																15.9
	Diffuser with opening	5		550	10																16.0

\* unworked port  
 \*\* worked port

Filter with tube



Filter with diffuser

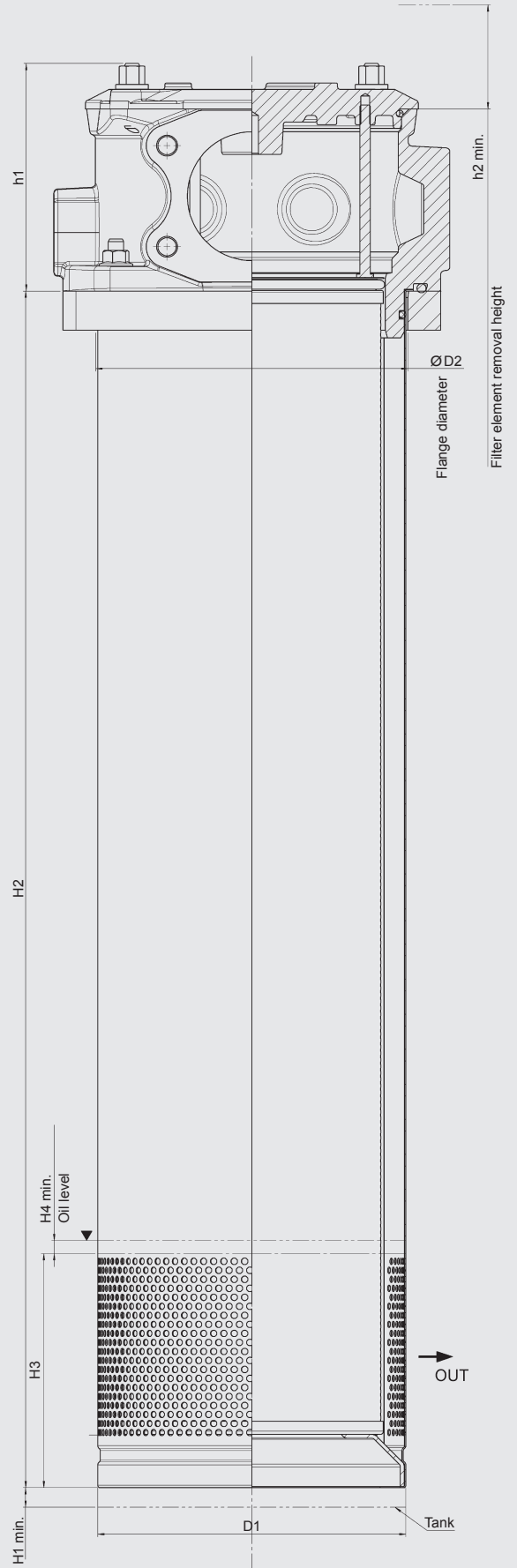

### Filter with diffuser (opening with grille)

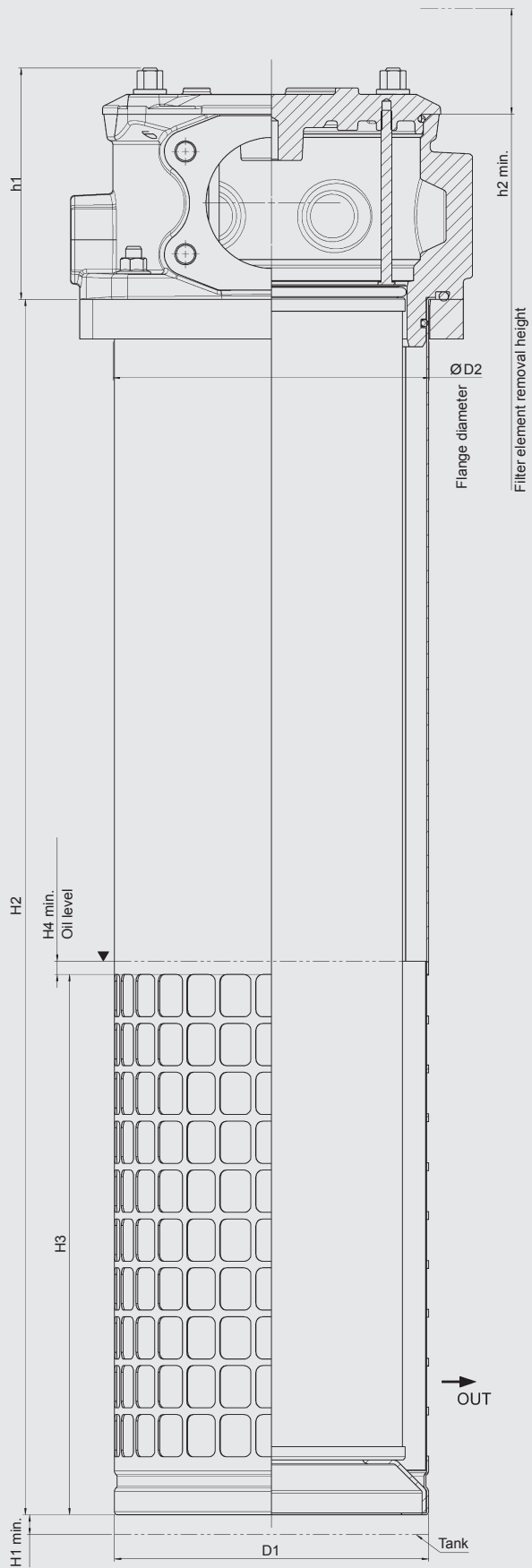

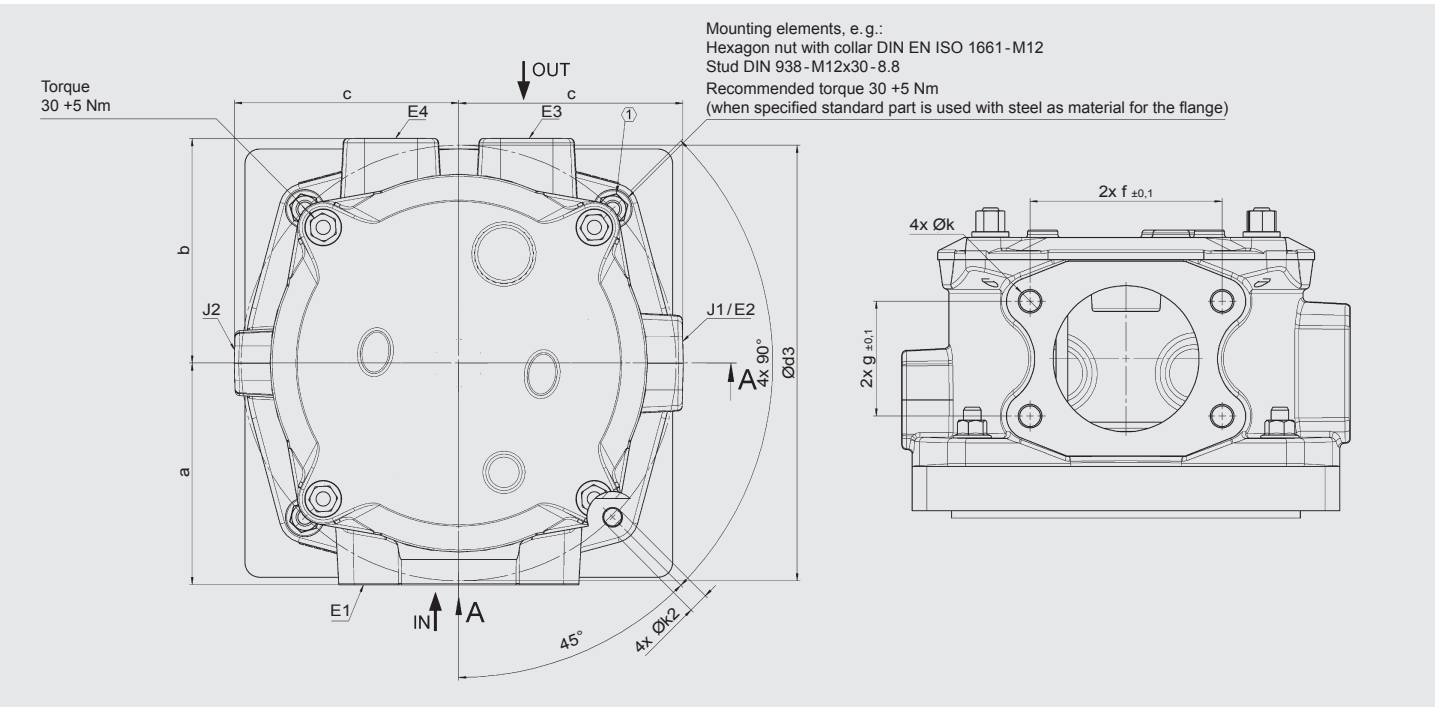

Type	Design	H1	H2	H3	H4	h	h1	h2	h3	ØD1	ØD2	Ød3	a	b	c	f	g	Øk	Øk2	Weight incl. element [kg]
RFT 1800	with tube	35	920	-	130	73	175	900	19	237.5	239.5	295	152*	152*	152*	SAE 4" 130.2	SAE 4" 77.8	M16 32 deep	13.5	29.3
	with diffuser	15		180	10															30.3
	Diffuser with opening			410	30.5															
RFT 2000	with tube	35	1200	-	130	73	175	1150	19	237.5	239.5	295	152*	150**	152*	SAE 3" 106.4	SAE 3" 61.9	M16 32 deep	13.5	34.7
	with diffuser	15		205	10															35.7
	Diffuser with opening			550	35.9															
RFT 2400	with tube	35	1200	-	130	73	175	1180	19	237.5	239.5	295	152*	150**	152*	SAE 3" 106.4	SAE 3" 61.9	M16 32 deep	13.5	35.8
	with diffuser	15		205	10															36.8
	Diffuser with opening			550	37.0															

\* unworked port

\*\* worked port

## 5. SPECIFICATIONS FOR THE TANK FLANGE

1. In the filter mounting interface, the tank flange should have a maximum flatness of 0.3 mm and maximum roughness of Ra 3.2 µm.
2. In addition, the mounting interface should be free from damage and scratches.
3. The fixing holes of the flange must be blind, or stud bolts with threadlocker must be used to fix the filter. As an alternative, the tank flange can be continuously welded from the inside.
4. Both the tank sheet metal and the filter mounting flange must be sufficiently robust so that neither deform when the seal is compressed during tightening.

### 5.1 RFT 0170, 0230, 0300, 0400

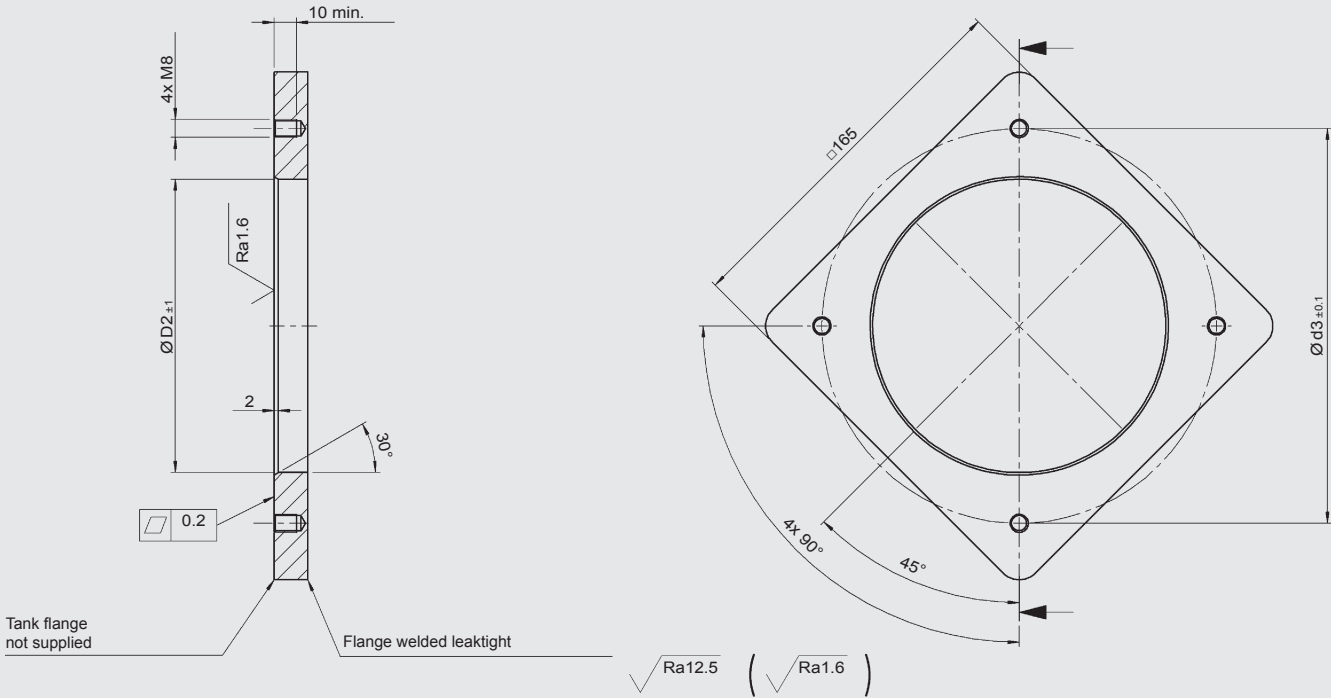

### 5.2 RFT 0310, 0410, 0500

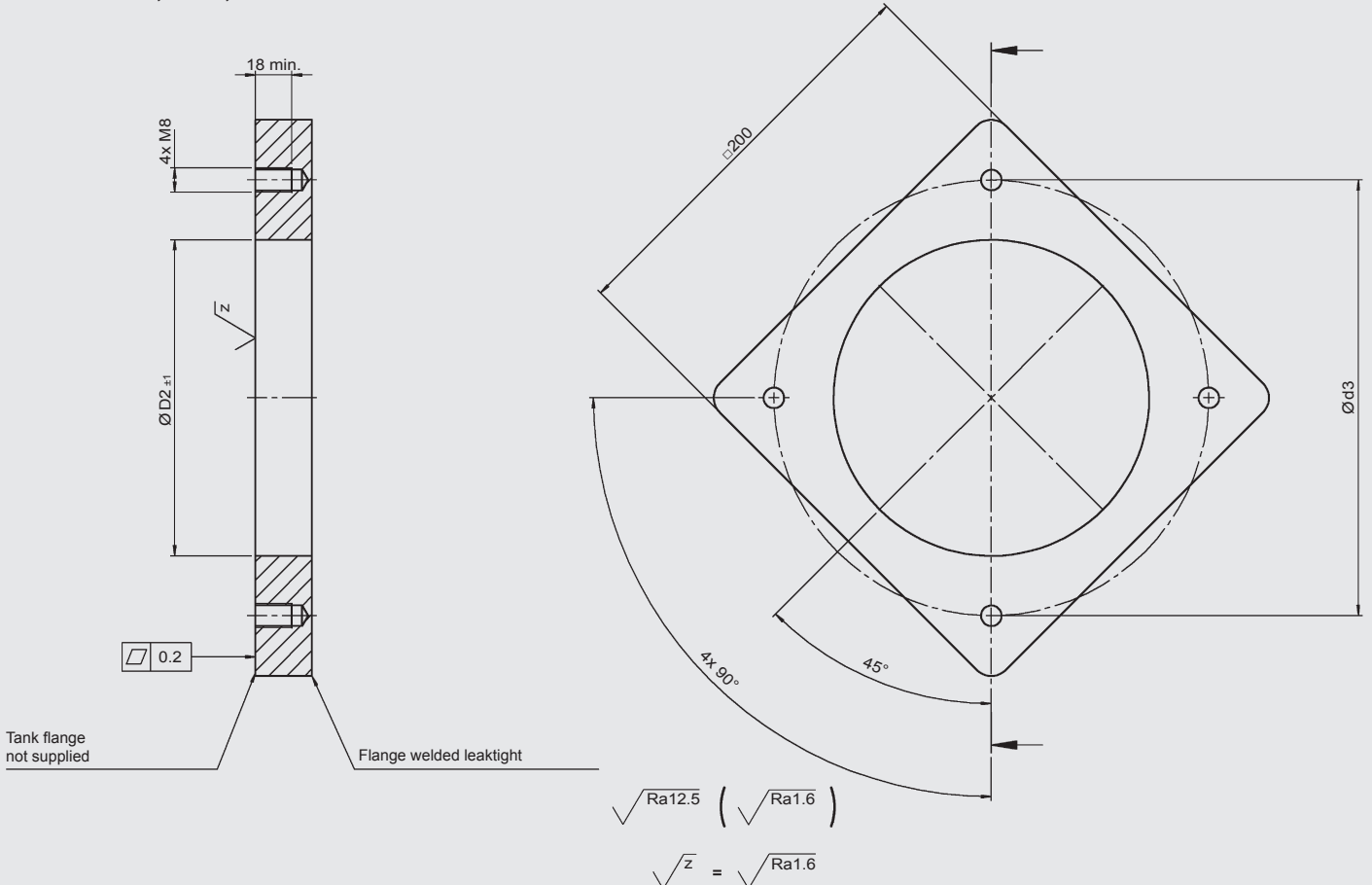

### 5.3 RFT 0600, 0800, 1200

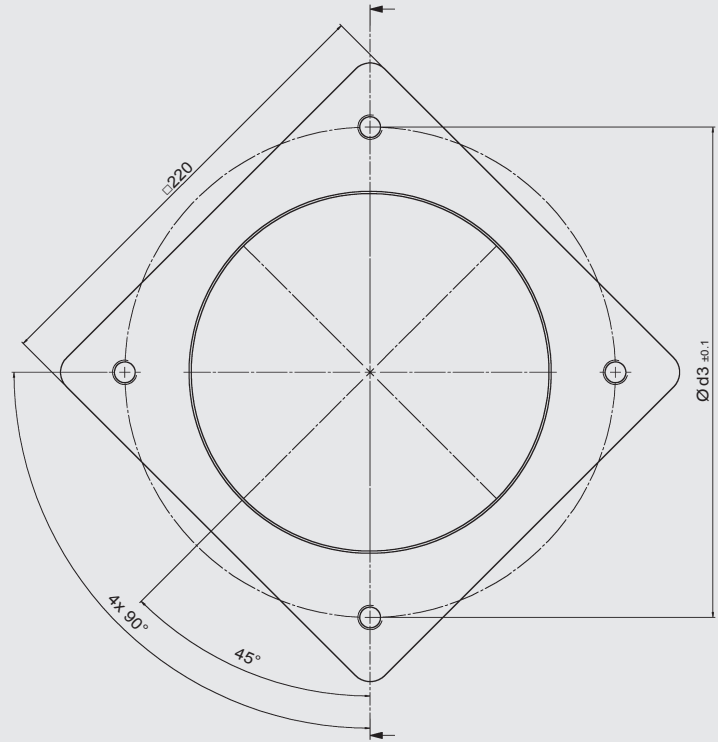
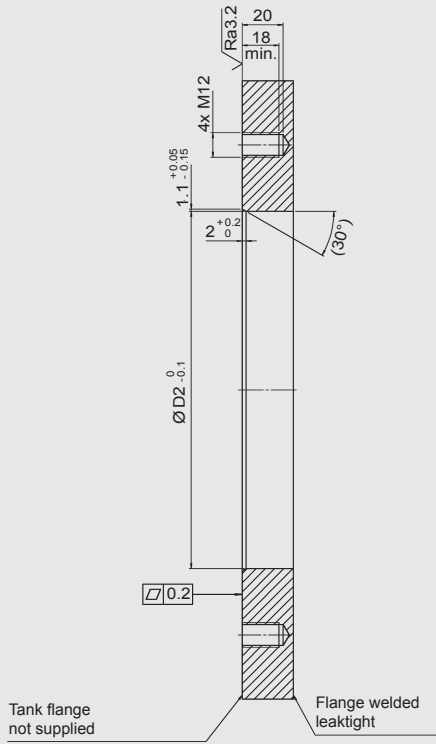

$$\sqrt{Ra12.5} \quad \left( \sqrt{Ra3.2} \right)$$

### 5.4 RFT 1800, 2000, 2400

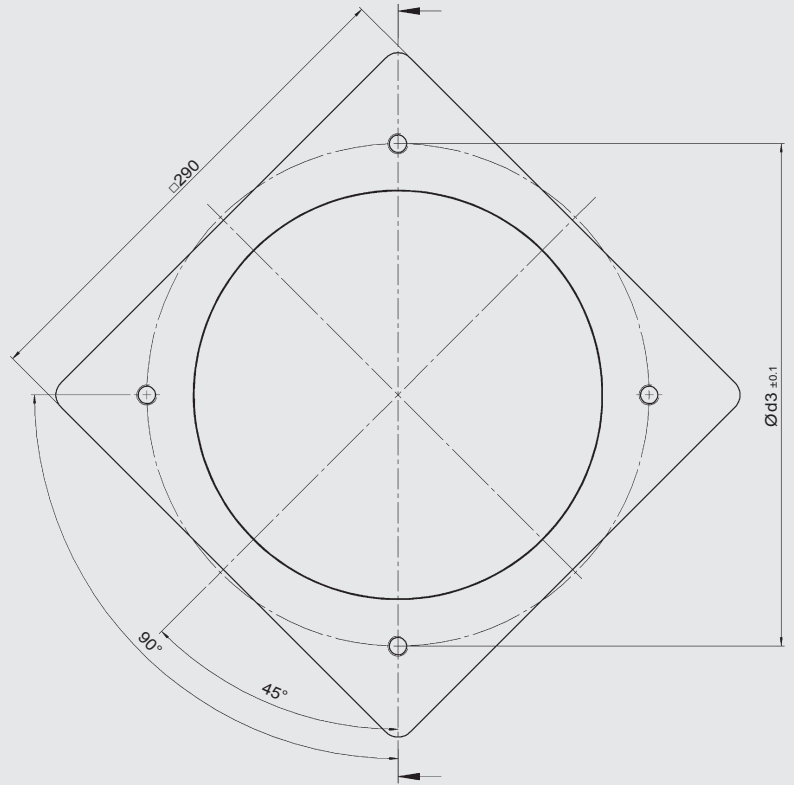
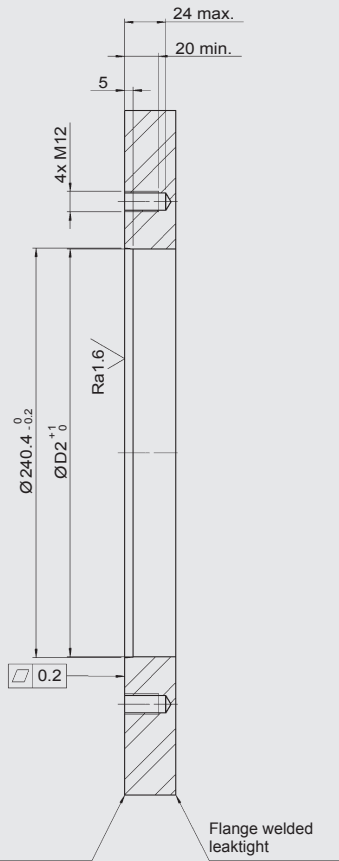

$$\sqrt{Ra12.5} \quad \left( \sqrt{x} = \sqrt{Ra3.2} \right)$$

---

---

---

---

**NOTE**

The information in this brochure relates to the operating conditions and applications described.  
For applications or operating conditions not described, please contact the relevant technical department.  
All technical details are subject to change without notice.

**HYDAC Filtertechnik GmbH**  
Industriegebiet  
**D-66280 Sulzbach/Saar**  
Tel.: +49 68 97 509-01  
Fax: +49 68 97 509-300  
Internet: [www.hydac.com](http://www.hydac.com)  
e-mail: [filter@hydac.com](mailto:filter@hydac.com)